

HFX SERIES



The Ultimate in
Waterjet Sophistication

NEXT GENERATION WATERJETS

Introducing the HJX series –
the next generation of our globally
popular HJ waterjet range.

Featuring our new hydrodynamic, slimline
design and advanced materials for redefined
performance, HJX is our smallest, yet high
performance, waterjet to date. HJX is proof
that the best things really do come in the
smallest packages.

Compact Design. Outstanding Performance. Effortless Installation.

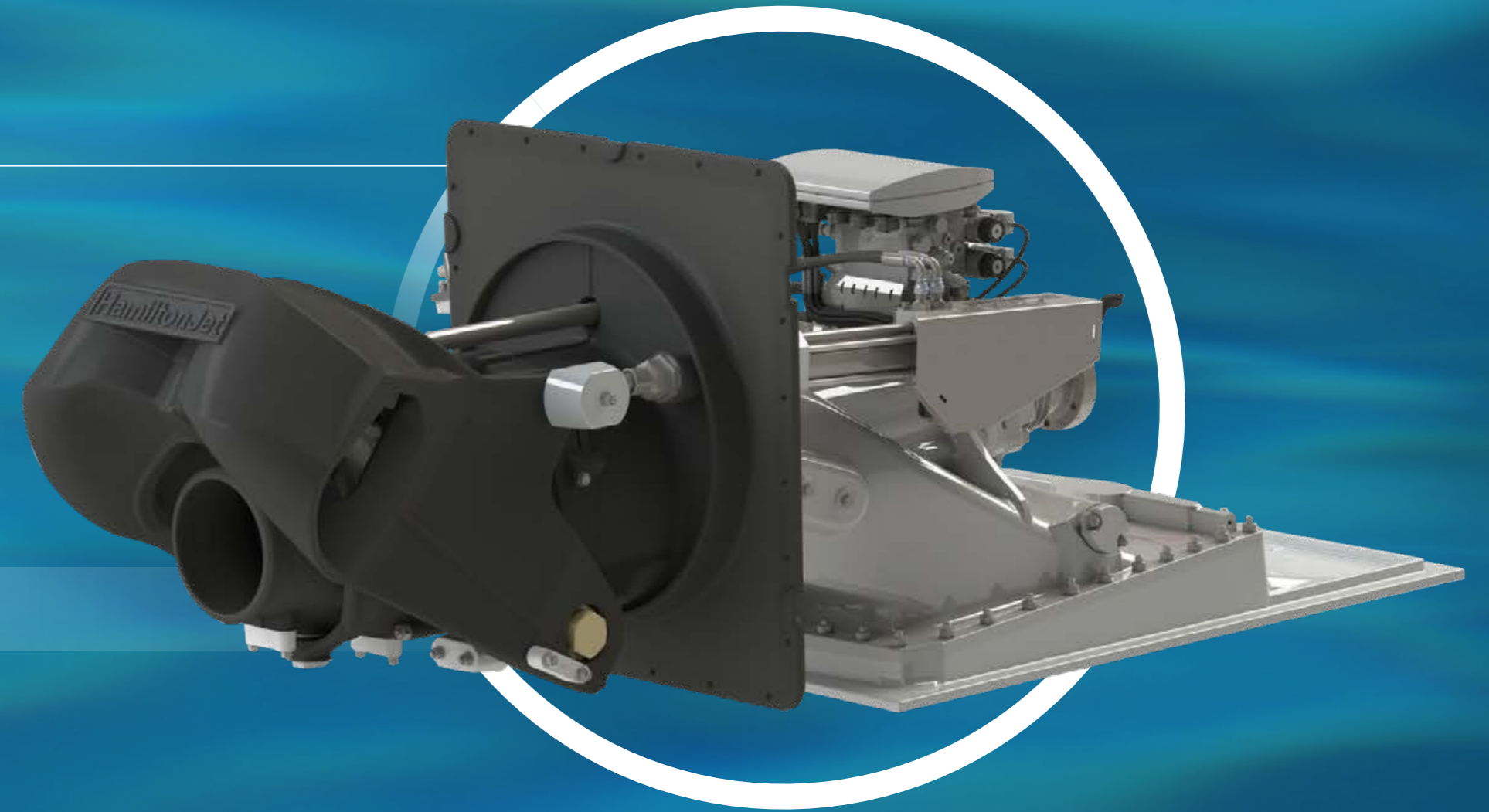



COMPACT DESIGN

HJX is our most compact waterjet.

It features a compact inboard footprint, narrow jet spacing and a low profile design. It means all HJX models are capable of being installed through the transom late in the build, reducing overall vessel installation costs. The fully integrated hydraulics and controls use space efficiently and ease incorporation into any platform.

The compact inboard footprint make HJX waterjets ideal for vessels up to 25 metres (vessel dependant), particularly Military Patrol, Aquaculture, Search and Rescue and recreational boats.



OUTSTANDING PERFORMANCE

HJX packs a punch.

Continuing our drive to design waterjets that deliver the ultimate combination of high speed efficiency with low speed capability, HJX ticks both boxes.

High speed performance.

At maximum power, the HJX series delivers 4-6 percent more thrust at higher speeds than the HJ series waterjets.

Exceeding all expectations, HJX is also capable of achieving speeds in excess of 50 knots when matched with suitable engines and hull design.

HJX utilises our patented low-loss JT steering systems, that are now standard across all our waterjets. These steering systems save fuel when course keeping and minimise speed loss during tight turns.

Low speed capability.

Featuring our new standard cavitation resistant intake and pump designs, the HJX series achieves **15-20 percent** more bollard pull and greater sway thrust than the previous HJ series.

This increased capability improves the manoeuvring response, position holding capability and vessel acceleration of the entire HJX range.



EFFORTLESS INSTALLATION

The compact inboard footprint, narrow jet-spacing and low-profile design make HJX series waterjets effortless to install.

Waterjet Installation

The compact size of the entire HJX series means all models are capable of being installed through the transom late in the build reducing overall vessel installation costs and improving construction efficiencies.

The fully integrated hydraulics and controls maximise the use of space and reduce the additional component costs during vessel construction.

Powertrain Compatibility

HJX is compatible with a diverse range of engines from global manufacturers. Our wide range of impeller ratings allow optimal engine and direct drive selection to reduce drivetrain cost and complexity.

Control Options

HJX is offered with a wide range of control options, including AVX, blue ARROW and manual controls.

Mechanical-Hydraulic

All HJX series waterjets are compatible with our HSRX, HFRC and HSRC controls.

blueARROW

blueARROW is our current electronic control system for our smaller waterjets. blueARROW allows even inexperienced boaters to harness the full manoeuvring benefits of waterjets through simple control of engine throttle, gearbox, reverse and steering deflectors.

AVX

AVX is our next generation of vessel controls redefining the operator experience to deliver mission-critical confidence, even in the toughest conditions. AVX is future-ready, underpinning our skipper assistance and autonomous solutions, and features our intuitive MouseBoat 3-Axis controller.



HJX FEATURES

HJX waterjets are designed with performance in mind. They're delivered to you tried, tested and ready to work the way you want them to.

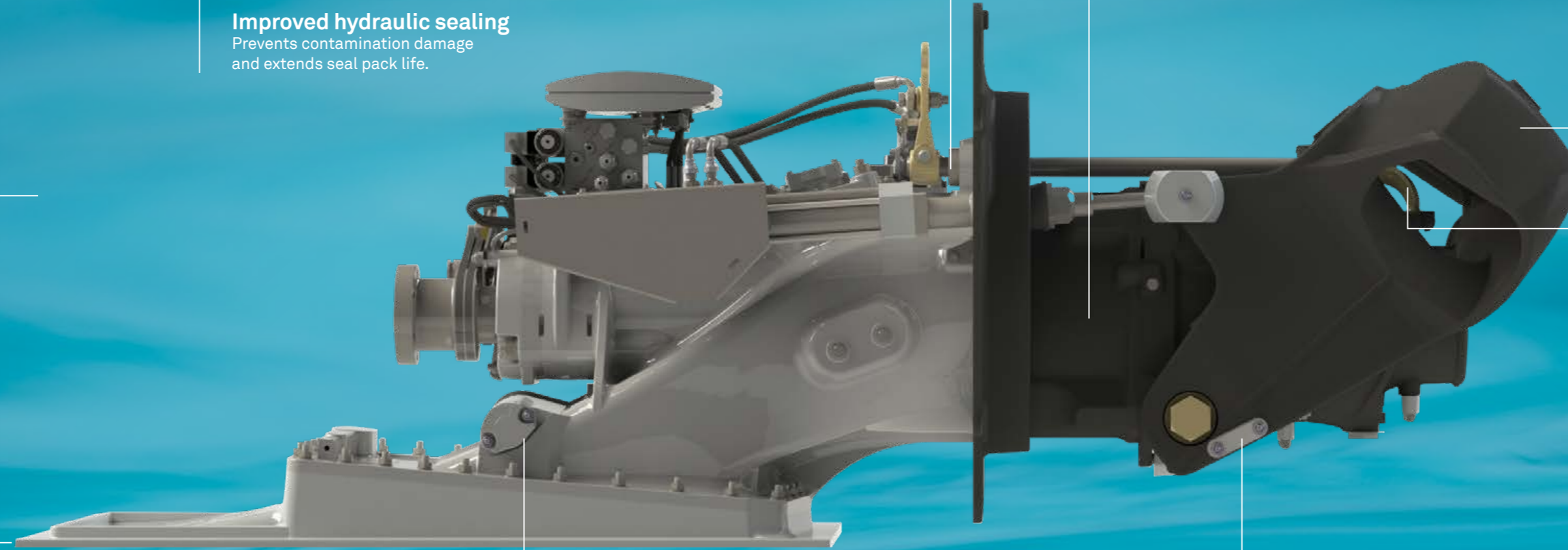

Improved hydraulic sealing

Prevents contamination damage and extends seal pack life.

New hydrodynamic design

Our newly optimised waterjet intake and parallel bore, axial flow design increases high speed efficiency for speeds in excess of 50 knots (vessel dependent). This delivers greater bollard pull for better position holding capability, manoeuvrability & acceleration.

Compact reverse duct

For even easier through transom installation.

Improved steering systems

More precise manoeuvring, minimised performance loss in turns and lower loads at the helm.

New screen design

The new aerofoil shaped screen bars improve overall waterjet efficiency, while the new intake makes the inboard footprint more compact.

Optional Screen Rake

All HJX jets come with the option of a factory fitted screen rake for the removal of weed or debris.

Refined anode layout

Extends product life and better aligns maintenance schedules.



CASE STUDY

ARES Patrol Boat

HJX29 will power 122 patrol boats for the Turkish Coastguard border control fleet.

The project will see each of the 12-metre Fibreglass Reinforced Plastic [FRP] and carbon composite boats equipped with twin HJX29 waterjets controlled by blueARROW.

HamiltonJet's Istanbul-based distributor Nemomarin is running the project with ARES Shipyard in Antalya. The build starts in late 2020.

“The project represents the largest volume serial production in Turkey's shipbuilding history, and it will certainly put a significant record in the world's shipbuilding archives as well. The project is planned to last five years and will involve construction and delivery of 122-ARES 35 FPB boats to meet the needs of the Turkish Coastguard. We will deliver six boats every two months based on our production programme.” Utku Alanc, CEO of ARES Shipyard

VESSEL SPECIFICATIONS

- Service:** Patrol vessels
- Location:** Turkey
- Length:** 12 metres
- Builder:** ARES Shipyard
- Owner:** Turkish Coastguard
- HamiltonJet:** Twin HJX29 waterjets and blueARROW controls

WORLD-CLASS PRODUCT SUPPORT

We are backed by more than 70 years in business as the pioneer and market leader in waterjets and controls.

Our product support and parts availability is truly class-leading. With a global network of regional offices and over 50 appointed distributors, help is always on hand. No matter where you are, in the unlikely event of a problem, downtime is minimised.

Our products all come with a commitment to at least 20 years' support after the end of series production*.

*This applies to all HamiltonJet products which reach series production and can be extended longer if a particular project requires it. Beyond this point, we still endeavour to keep you moving where possible.





WORK WITH US

Over the decades we've become trusted partners to boat builders, naval architects and marine operators around the globe. They tell our story better than we do, so if you'd like some references, please get in touch.

Our network is global. Wherever you are, you'll find experienced distributors supported by our own regional office staff to assist you with your project. We'll walk you through the process and can deliver simple or complex projects.

Our market experience is extensive. It covers offshore, pilot, rescue, fire, military, patrol, windfarm, fast ferry, fishing, aquaculture and recreational applications.

HamiltonJet Global Headquarters

PO Box 709
Christchurch, 8140
NEW ZEALAND
P: 0064 3 962 0530
E: marketing@hamiltonjet.nz
www.hamiltonjet.com

HamiltonJet Regional Offices

Americas
14680 NE North
Woodinville Way
Suite 100, Woodinville
WA 98072
UNITED STATES
OF AMERICA
P: 001425 527 3000
or 800 423 3509
E: marketing@hamiltonjet.com

EMEA

Unit 26, The Birches
Industrial Estate
East Grinstead,
West Sussex RH19 1XZ
UNITED KINGDOM
P: 00441342 313 437
E: marketing@hamiltonjet.uk

Asia

1 Toh Tuck Link
#04-01
SINGAPORE 596222
P: 0065 65672202
E: marketing@hamiltonjet.sg